

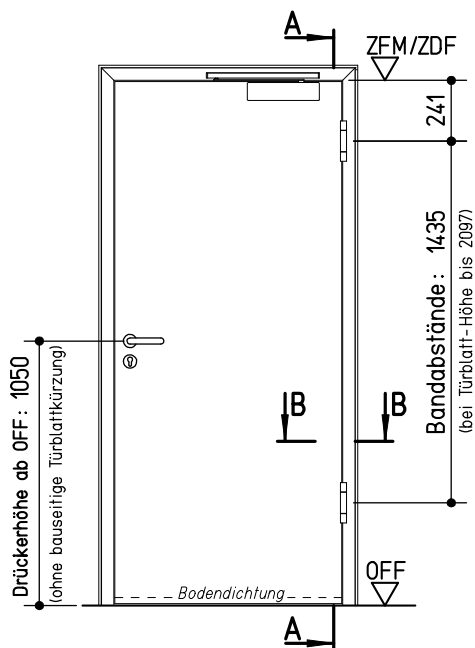

# Ansicht von der Bandseite

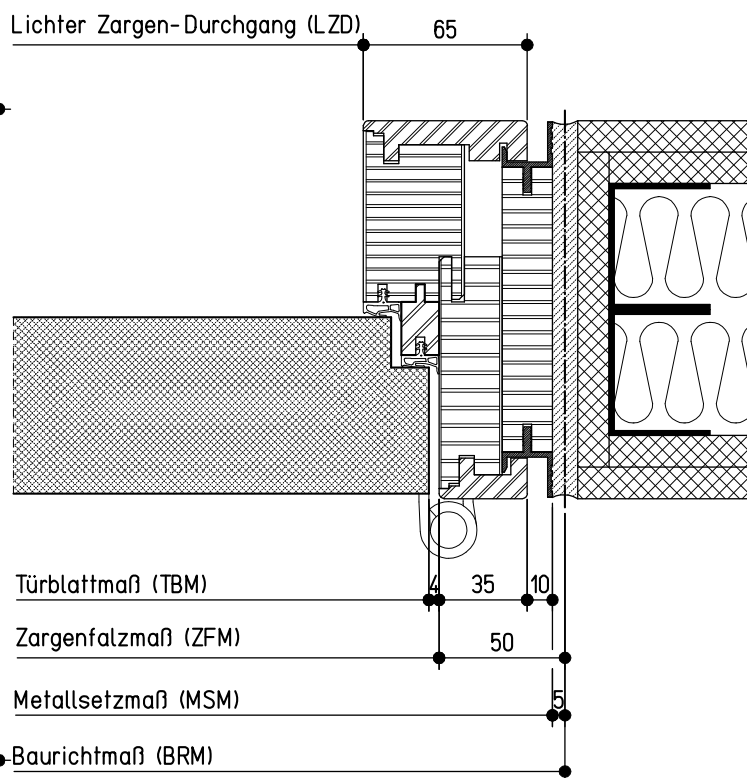
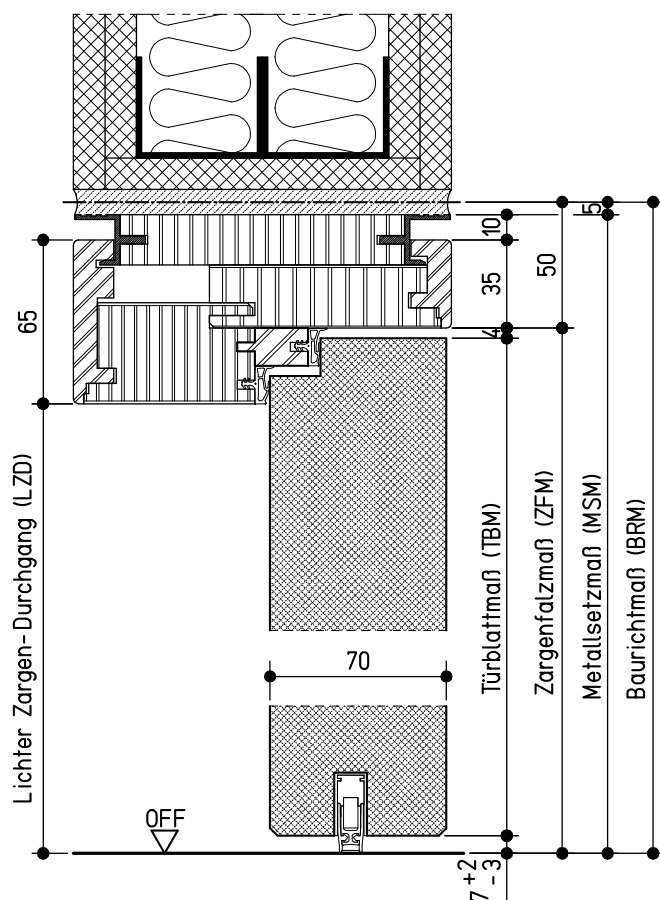

Vertikalschnitt A-A

Horizontalschnitt B-B



neuform-Türenwerk Hans Glock GmbH & Co. KG, 71729 Erdmannhausen		
T 30-System S 'H 31 S15 DF' (70 mm Türblatt, stumpf) Spiegel 35/65 sturzhoch, Modell 100 (Montage-Trennwand), $R_w, P=42$ dB		
		Maße in mm
		K-08-HL31S15DF_100-02